

BRASS GLOBE VALVE SOFT SEAT 200 PSI MODEL LVBGV

- Working Pressure 200 WOG
- Threads to ANSI B1.20.1 (NPT)

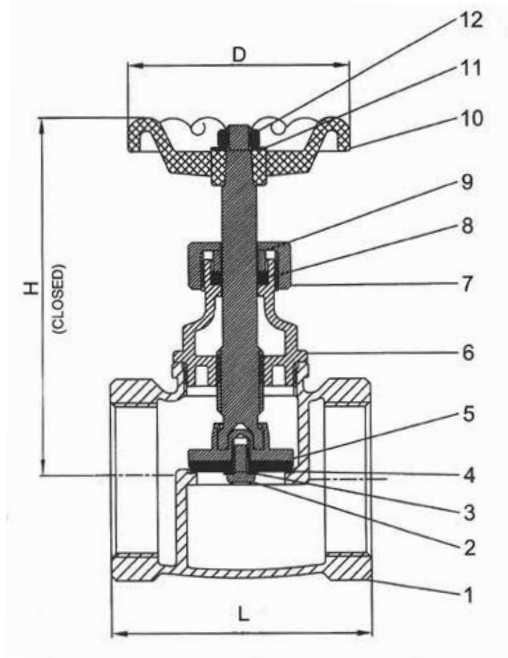

SIZE (in)	D (in)	H (in)	L (in)
1/4	2.17	2.32	1.77
1/2	2.17	2.85	1.89
3/4	2.17	2.93	2.17
1	2.56	3.43	2.48
1-1/4	1.68	4.08	2.91
1-1/2	2.95	4.89	3.31
2	3.35	5.38	3.94

NOMENCLATURE & MATERIAL LIST			
NUMBER	DESCRIPTION	MATERIAL	SPEC. ASTM
1	BODY	CAST BRASS	B584 C85700
2	SEAT SCREW	BRASS ROD	B111 C28000
3	WASHER	STAINLESS STEEL	S.S.304
4	SEAT	NBR	
5	DISC HOLDER	BRASS ROD	B16 C36000
6	BONNET	FORGED BRASS	B124 C3700 (3/4"-1")
		CAST BRASS	C85700 (1 3/4"-2")
7	PACKING NUT	BRASS ROD	B16 C36000
8	PACKING	TEFLON	PTFE
9	PACKING GLAND	BRASS ROD	B16 C36000
10	HANDWHEEL	CAST IRON	A48 CLASS/NO. 30
11	NAMEPLATE	ALUMINUM	COMMERCIAL
12	HANDWHEEL NUT	STEEL	A29.GR1010

PROJECT	APPROVAL STAMP
PROJECT:	<input type="checkbox"/> APPROVED
ADDRESS:	<input type="checkbox"/> APPROVED AS NOTED
ENGINEER:	<input type="checkbox"/> NOT APPROVED
SUBMITTAL DATA:	REMARKS:
NOTES 1:	
NOTES 2:	